



GENERAL INFORMATION SECTION



This manual contains programming, operation, and complete parts and electrical wiring diagrams.

The controller is a microprocessor which will permit pricing per selection from 0.00 to 99.99. This machine also has space-to-sales programming as well as energy savings modes.

SXY Model Numbers	240-XY	320-XY
Dimensions H x W x D	72" x 34" x 38.5"	72" x 41.5" x 39"
Shipping Weight	750 lbs	800 lbs
Shelves	5 - 7	5 - 7
Trays per shelf	3	4
Facings / shelf	6	8
Total # of facings:		
5 shelf	30	40
7 shelf	42	56
Total capacity:		
20 oz bottle	240	320
12 oz can	378	504

Dimensions and shipping weight will vary slightly due to manufacturing tolerances, shipping boards and whether or not coinage is installed.



WARNING

Load this unit with shelf-stable product ONLY.

This unit is not equipped to safely vend perishable product.

Loading this unit with improper product may result in serious illness or injury to the consumer.

1125135



INITIAL SET-UP

A. UNPACKING

Remove all plastic film, cardboard and tape from the outside of the vendor. Loosen any shipping devices used to secure interior parts during shipment (backspacer, shims or spacers).

To remove shipping boards from base, raise vendor on a well-stabilized lifting device. Remove the leveling bolts which hold the boards in place and remove the boards. Replace bolts to equal heights in the threaded holes. Another method to remove shipping boards is to split the boards apart. Using a pinch bar or a heavy screwdriver and hammer, insert tool into the slots and force the boards apart. **The leveling legs shall not raise the vendor more than 1 1/8 inch above the ground.**

B. POSITIONING

IMPORTANT: PLACE THE VENDOR IN DESIRED LOCATION AT LEAST THREE INCHES (7.6CM) AWAY FROM ANY REAR OBSTRUCTION. This is for proper air flow through the refrigeration compartment. The refrigeration system requires rear to front air circulation for proper operation.

C. POWER SUPPLY CONNECTION

CAUTION: DO NOT USE AN EXTENSION CORD!

The vendor's power requirements will vary depending upon the country it was purchased for. To verify the power requirements of the vendor, check the serial plate located on the hinged side of the outer door. The power requirements are listed on the serial plate.

To insure safe operation of the vendor, the vendor's power supply must be a properly grounded and polarized outlet. Before plugging the vendor into the outlet, test the outlet to confirm it will meet the vendor's power requirements. If the power supply of the outlet is different from the power requirements of the vendor, a transformer may be necessary.

If the power requirements are not properly met, contact a licensed electrician and have the necessary correction made.

Should you require additional information, contact the Technical Services Department of the SandenVendo America, Inc. office in your area.

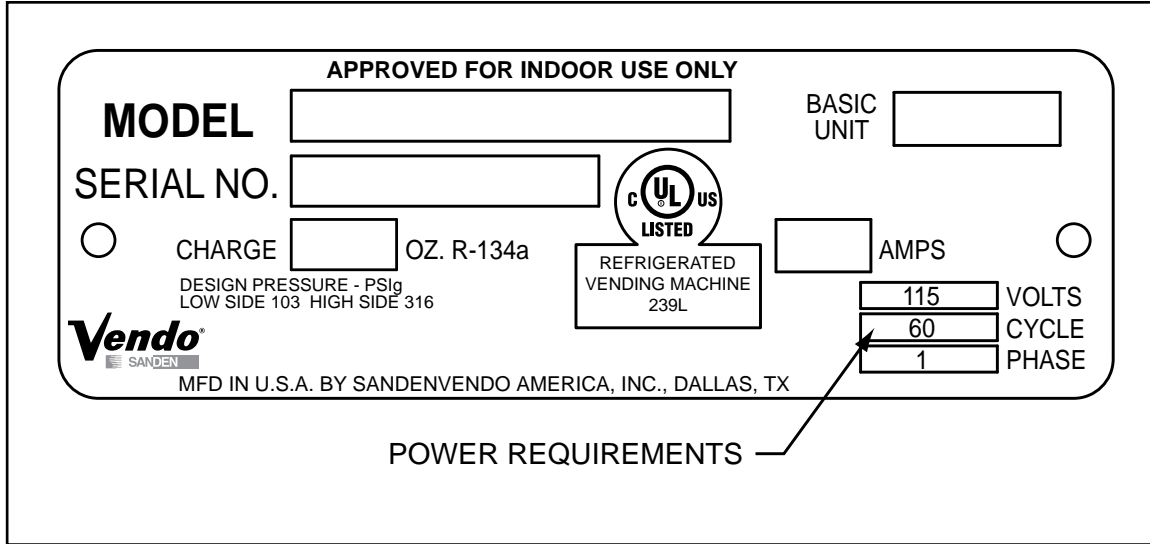

FIGURE 1

NOTE: The **Model** number of the vending machine is located on the top, left hand corner of the serial plate. A typical model number could read “320GFT001”. The 320 is the model number, GFT represents the product line of the vendor, and the remaining digits tell what options are included.

TRAY LABEL INSTALLATION

Insert column labels as shown in Figure 2. The column number is a two digit number where the first digit is a shelf number and the second number is called out a column on that shelf. Shelves are numbered starting with "1" from the top shelf. Columns are numbered starting from "0" on the left most column. So the leftmost column on the top shelf is "10" and toward the right, the column number is increased by the increment of 1 which is called out "11", "12", and so on. The next shelf down leftmost column is numbered "20" and the shelf under that starts with number "30" and so on.

NOTE: A shelf that does not have trays on it should not be numbered.

Selection button number labels can be inserted in each product pusher as indicated.

BASIC LOAD SET-UP

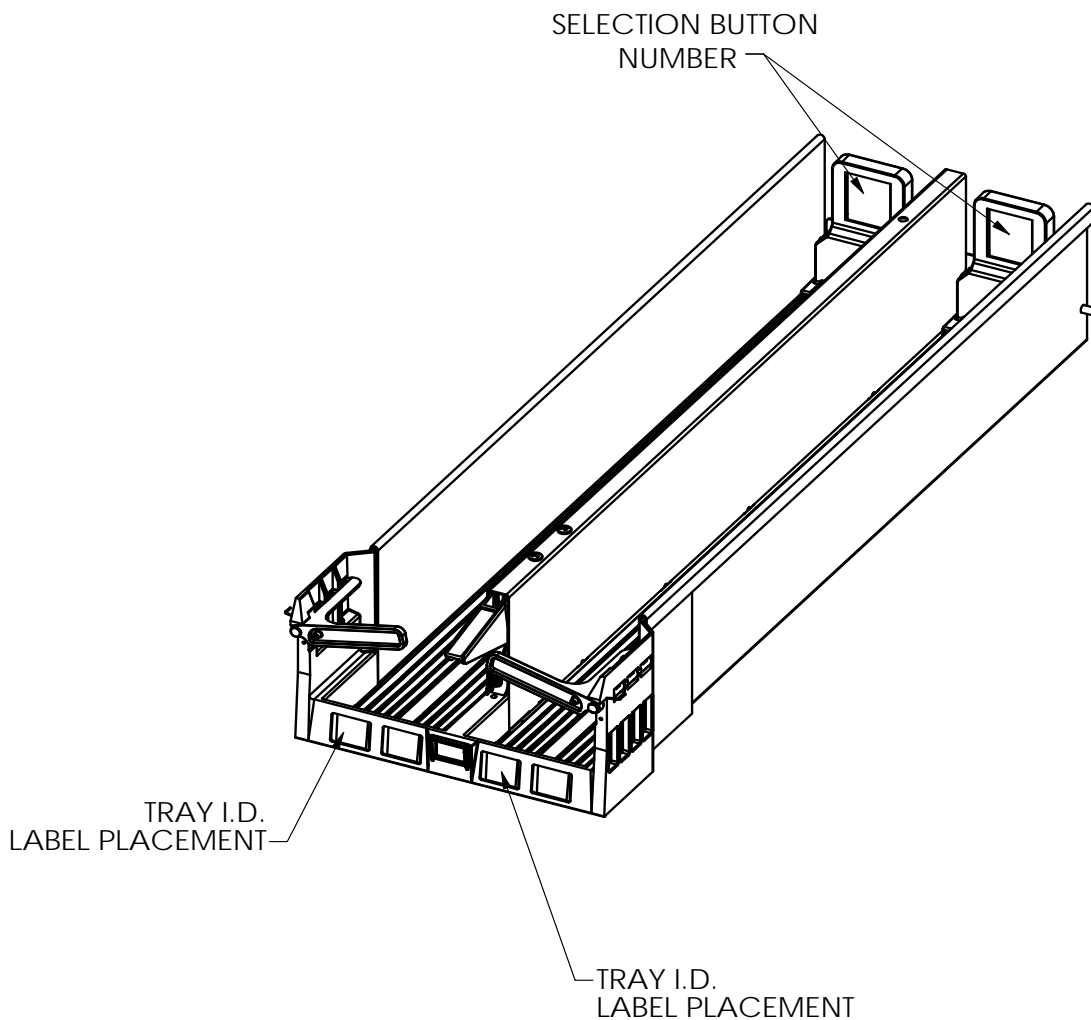

FIGURE 2

LOADING INSTRUCTIONS

1. Withdraw the tray from the cabinet by lifting slightly before pulling toward you. The tray will tilt down slightly to ease loading. Pull forward until the tray stop is reached.
2. Push the product pusher to the rear of the tray. The product pusher should lock into place in this position. Add new product to the tray. When the tray is pushed back onto the shelf, the product pusher will automatically unlock, and move to the back of the product queue. Ensure the tray is fully latched into position on the shelf.

It is suggested that one tray is loaded at a time, to maintain stability.

VEND MECHANISM PART DESCRIPTION

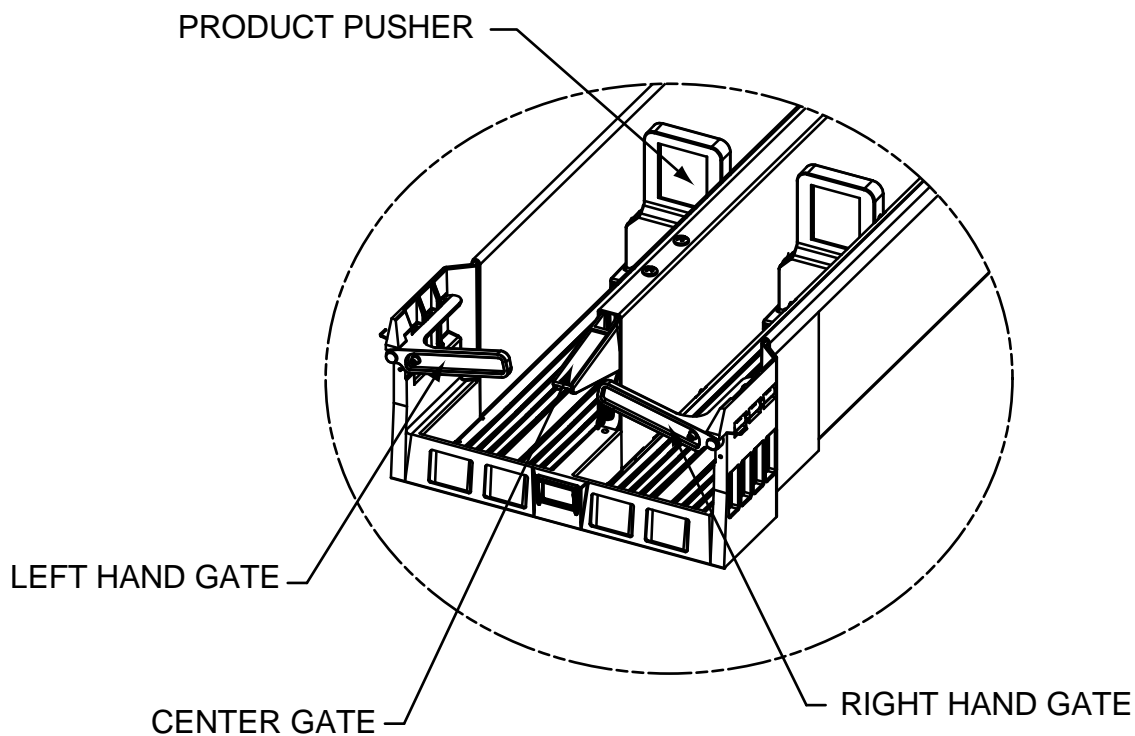

TRAY ASSEMBLY DETAIL

FIGURE 3

SXY VENDOR PART DESCRIPTION (CONTINUED)

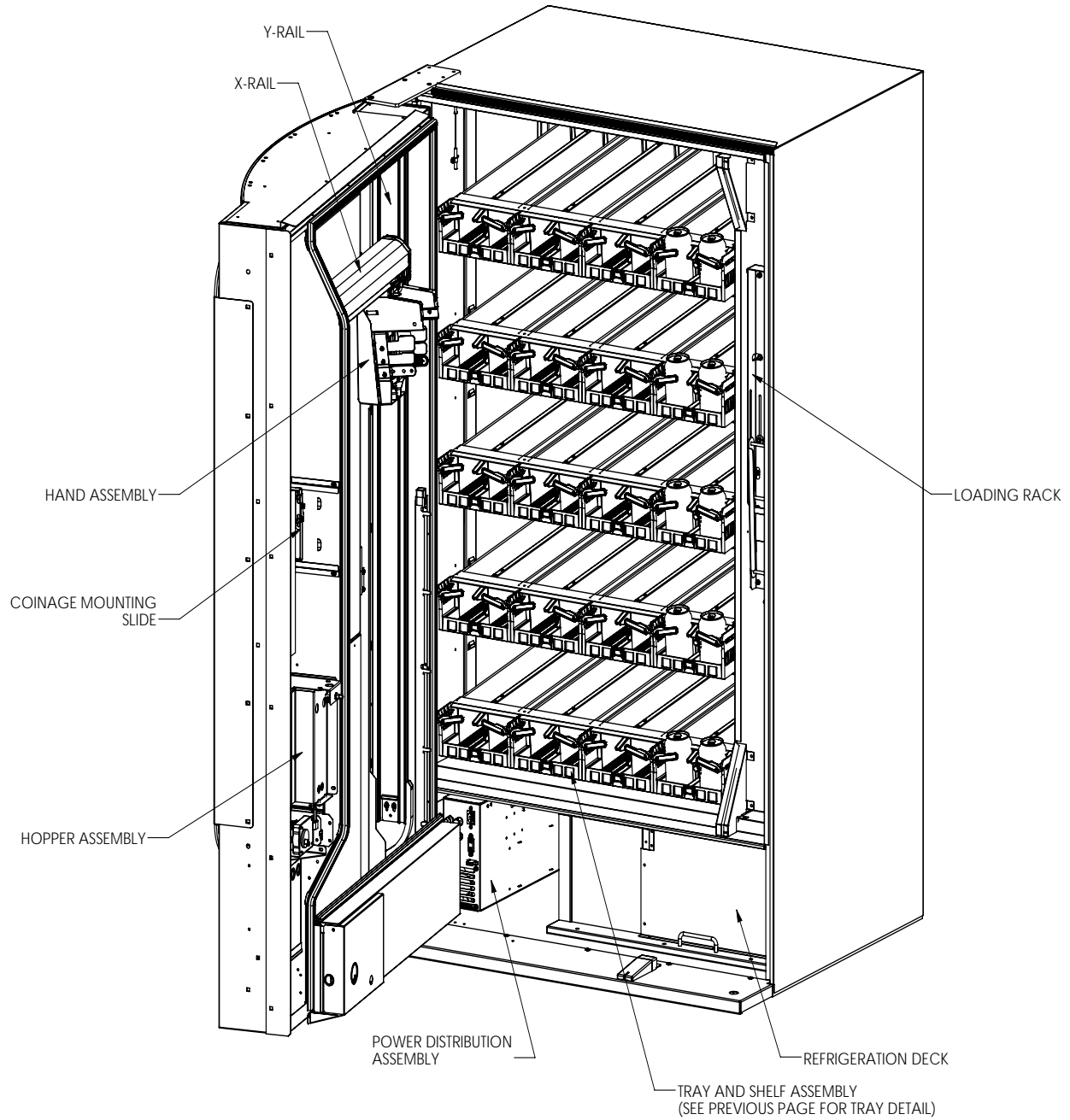

FIGURE 4



NOTES